

STORAGE SUPPORT SOLUTIONS

PDE

TECHNOLOGY
CORPORATION

PRODUCTION • DESIGN • ENGINEERING



E301 STACKABLE DRIVE ENCLOSURES

- Provides an external housing solution for a 5.25" or 3.5" drive - SCSI -50 or 68 pin, FIREWIRE, USB2 or fibre channel interfaces available.
- Turnkey solution includes:
 - Dedicated bezel for drive
 - Data cables
 - Drive mounting hardware
- Highest quality on the market
 - First tier covered power supply and fan
 - PDE is ISO 9001
 - 1 year warranty
- Contemporary Design
 - Front mounted power switch
 - Standard logo indent for private labeling
 - Available in black or beige plus custom colors
- Stackable and Convertible
 - All drive types stack with universal footprint
 - Enclosure can sit vertically or horizontally
- Maximum flexibility
Can be configured for:
 - 1/2 height hard drive
 - Low profile hard drive
 - 1/2 height 5 1/4" drive
 - 3.5" tape drive
 - 3.5" zip/jaz drive
- Designed to exceed requirements for 14,000 RPM and LVD Drives

PDE TECHNOLOGY CORPORATION
www.pdetechology.com

Distributed by:

Sierra Technologies, LLC

864-458-9035

Sales@SierraTechnologies.com

Headquarters

11522 Markon Drive
Garden Grove, CA 92841
Phone: 714-799-1704
Fax: 714-799-1705
E-mail: info@pdetechnology.com

European Office

Sterling House
Stroudley Road
Basingstoke
RG24 8UG
England
Phone: 44 (0) 1256 811460
Fax: 44 (0) 1256 811396
E-mail: info@pdetechnology.co.uk
Sales E-mail: sales@pdetechnology.co.uk

COOLING SYSTEM

- 50X50X10 Hi volume cooling fan

SPECS:

- Size.....50x50x10 mm
- Air Flow....8 CFM
- RPM.....4300
- Power.....0.6 watts
- Sleeve bearing construction
- Locked rotor protection
- 4 pole DC motor design
- UL, CSA, TUV approved

POWER SYSTEM

- 50 watt auto sensing power supply

SPECS:

- Input.....100-240
- Size..... L-151mm; W-44mm; H32.5mm
- mtbf 60,000 hours at full load (25°C)
- Short circuit protection with auto recovery
- Over voltage protection with auto recovery
- UL, CSA, TUV approved

Output Voltage	Min	Max	Tolerance	Rippled Noise	Regulation	
					Line	Load
+ 5v	.1A	4.0A	2%	50mv	2%	2%
+ 12v	.1A	3.0A	10%	120mv	2%	10%

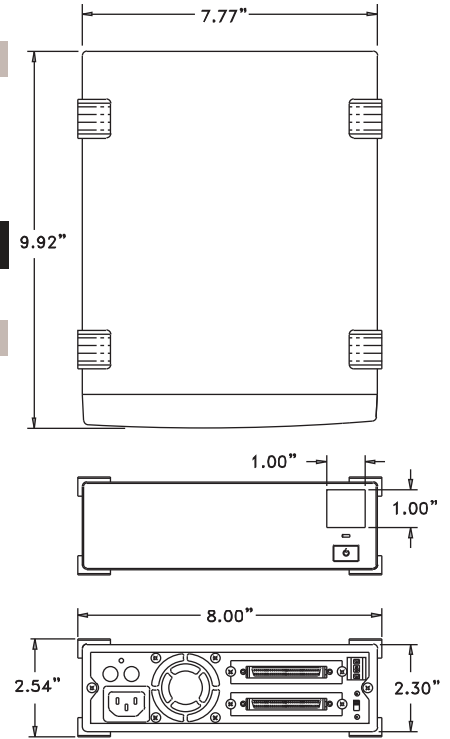

TESTING PROCEDURE

- Hi Pot
- Voltage
- Cosmetic
- Continuity
- Functionality
- Ground
- Power Supply with Load
- Electrical
- Cooling System
- Mechanical

PART NUMBERS FOR MODEL E301

- 11-1018 E301 ENCL. FOR 3.5" HDD WIDE
- 11-2007 E301 ENCL. FOR CD WITH HD50 I/O
- 11-1023 E301 ENCL. FOR 5.25" TAPE DRIVE
- 11-1021 E301 ENCL. FOR 3.5" REM. MEDIA NARROW (1" or 1/2 height)
- 11-1019 E301 ENCL. FOR CD WITH C50 I/O
- 11-1020 E301 ENCL. FOR 3.5" REM. MEDIA WIDE
- 11-1022 E301 ENCL. FOR UNIVERSAL DISTRIBUTION (HDD, CD, Tape, bezels inc.)
- Other configurations available

APPROVALS

Designed to meet FCC and Safety Agency requirements



SPARE PARTS AND/OR OPTIONS

- Power Supply..... 25-1009
- Fan..... 25-1014
- HDD Bezel..... 22-1099
- CD Bezel..... 22-1071
- 3.5" x 1" open bezel..... 22-1070
- 3.5", 1/2 HT, open bezel..... 22-1072
- Wide (68 pin) data cable,1 drive 29-0036
- Narrow (50P) internal data cable 29-0066
- Wide SCSI ID kit..... 14-1065
- Narrow SCSI ID kit..... 14-1066
- Audio jack kit..... 14-1067
- 68 pin active terminator..... 14-1041
- 68 pin LVD mm terminator..... 14-1025
- C50 pin active terminator 14-1045
- HD50 active terminator..... 14-1043
- 3' external cable HD68m-HD68m..... 29-0029
- 3' external cable HD68m-UHDCI68m.... 29-0098
- 3' external cable HD68m-HD50m..... 29-0095

Weight with packaging Master Carton of 6 pieces is 31.2 lbs.
OEM/BULK Packaging is available

